

# HOMOGENIZER PRESSURE GAUGE

## SSKE18-1

### APPLICATIONS

- Sanitary, food & beverages
- Optional electric contacts
- Optional transmitter output
- Filled version



### FEATURES

- Dairy, Ice cream industries
- Pharmaceutical industries
- Sterilization applications

### HOMOGENIZER PRESSURE GAUGE, SSKE18-1

## DESCRIPTION

### General

**Design** : EN 837-3

**Accuracy** :  $\pm 1.6\%$  of full scale

**Ambient temperature** : -40...+65°C [without dampening liquid]  
-20...+65°C [with dampening liquid]

**Service temperature** : 10...150°C max.

**Pressure limits** : Steady pressure up to FS value

Fluctuating pressure up to 90% of FS value

Short time 1.3 x FS value for range up to 100 bar

Short time 1.15 x FS value for range above 100 bar

**Weld joints** : TIG argon arc welding

### Material of construction

**Sensing element** : Diaphragm

**Case & Ring material** : AISI 304 SS (Bayonet type)

**Diaphragm, Bourdon tube & Shank** : AISI 316L SS

**Movement mechanism** : AISI 304 SS

**Dial** : Aluminum, black graduation on white background

**Pointer** : Fixed, aluminum, black powder coated

**Gaskets & filling plug** : Neoprene

**Window** : Plexi glass

### Standard version

**Dial size** : DN100

**Range** : -1...600 bar

**Mounting pattern** : Direct, Bottom connection

**Process connection** : Without mounting flange

**Seal filling fluid** : Glycerine [10°C to 150°C]

**Ingress protection** : IP 65

**Execution** : Dry / Dry but fillable

### Filled versions

#### Glycerin

**Window** : Plexi glass

**Dampening liquid** : Glycerin 99.7%

### Temperature effect

When temperature of the measuring system deviates from reference temperature (+20°C) :

max error  $\pm 0.4\%$  / 10K of true scale value.

# HOMOGINIZER PRESSURE GAUGE SSKE18-1

## DIMENSIONAL DRAWING

Without mounting flange

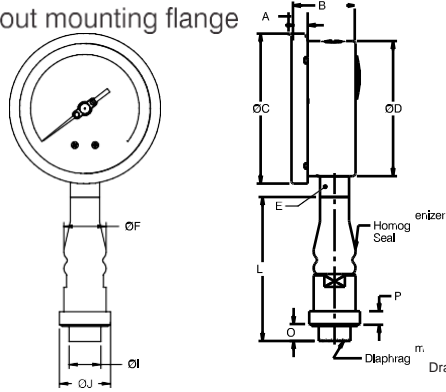

With mounting flange

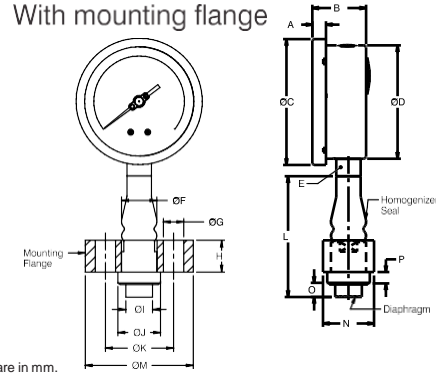

Drawing not to scale. All dimensions are in mm.

DN	A	B	ØC	ØD	E	F	I	J	L	O	P	Weight (grams)
100	12	48	111	100	SQ.22	31	23.5	37.5	106.5	11	11	1295

DN	A	B	ØC	ØD	E	ØF	G	H	I	J	K	L	M	N	O	P	Weight (grams)
100	12	48	111	100	SQ.22	31	18	28	23.5	37.5	80	106.5	95	45	11	11	1688

## ORDERING CODES

### MODEL

**SSKE18-1** Homoginizer Pressure Gauge

SSKE18-1

### DIAL SIZE

**D4** 4" / 100 mm

D2

M1

### MOUNTING CONNECTION

**P41** With mounting flange      **P42** Without Mounting Flange      **P43** 1 1/4" BSP(F) Union Nut

P42

### CASE FILLING

**F1** Dry      **F2** Dry but fillable      **F3** Glycerin filled

F2

### WETTED PARTS

**S02** AISI 316 SS      **S03** AISI 316L SS

S02

### INGRESS PROTECTION

**I1** IP 65      **I6** IP 68

I1

### RANGE

**0-250 bar** Please mention range required with the measurement unit  
[SSKE offer in all types of National & International measurement units, e.g. kg/cm<sup>2</sup>, psi, kPa, etc. with single or dual scales]

0-250 bar

### OTHER OPTIONS

**E16** 5 - point calibration certificate      **E31** Custom designed dial      **E32** Dial tag marking  
**E17** Material test certificate 3.1      **E21** Material test certificate 2.2      **E28** SS tag plate, AISI 316 SS  
**E27** SS tag plate, AISI 304 SS      **E47** Crimped case & ring

E16/E27

Ordering Example : SSKE18-1.D2.M1.P42.F2.S02.I1/0-250 bar/E16/E27

SHREE SAMARTH KRUPA ENGINEERS

Contact : +91 8155865961, +919586682557

prakash@shree-samarthkrupa.com, www.shree-samarthkrupa.com